



Viper Stretcher



Read this Manual and Retain
for Future Reference 

FERNO[®]

Instructions for Use

Jan 2024, Rev 2

Ferno Customer Relations

For ordering assistance or general information:

CANADA AND THE U.S.A.

Telephone (Toll-free)	1.877.733.0911
Telephone	1.937.382.1451
Fax (Toll-free)	1.888.388.1349
Fax	1.937.382.1191
Internet	www.ferno.com

ALL OTHER LOCATIONS

For assistance or information, please contact your Ferno distributor. If you do not have a Ferno distributor, please contact Ferno Customer Relations:

Ferno-Washington, Inc., 70 Weil Way
Wilmington, Ohio 45177-9371, U.S.A.

Telephone	Country Code +1.937.382.1451
Fax	Country Code +1.937.382.6569
Internet	www.ferno.com

Disclaimer

This manual contains general instructions for the use, operation and care of this product. The instructions are not all-inclusive. Safe and proper use of this product is solely at the discretion of the user. Safety information is included as a service to the user. All other safety measures taken by the user should be within and under consideration of applicable regulations and local protocol. Training on the proper use of this product must be provided before using this product in an actual situation.

Retain this manual for future reference. Include it with the product in the event of transfer to new users. Additional free copies are available upon request from Customer Relations.

Proprietary Notice

The information disclosed in this manual is the property of Ferno-Washington, Inc., Wilmington, Ohio, USA. Ferno-Washington, Inc. reserves all intellectual property rights, proprietary design rights, manufacturing rights, reproduction use rights, and sales use rights thereto, and to any article disclosed therein except to the extent those rights are expressly granted to others or where not applicable to vendor proprietary parts.

Limited Warranty Statement

The products sold by Ferno are covered by a limited warranty, which is printed on all Ferno invoices. The complete terms and conditions of the limited warranty, and the limitations of liability and disclaimers, are also available upon request by calling your local Ferno distributor or Ferno at 1.800.733.3766 or 1.937.382.1451.

Adverse Event Notice

In the event of an adverse event or serious incident related to the use of this device, the end user/operator must report the incident to Ferno-Washington, Inc. at 70 Weil Way, Wilmington, Ohio 45177 USA, 1-877-733-0911, or via email at tscoordinator@ferno.com. If the incident occurred in the European Union, report it to Ferno's Authorized EU Representative and the competent authority of the Member State in which the end user is established.

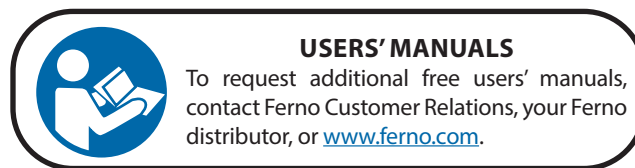

Unique Device Identification (UDI)

Ferno complies with the United States Food and Drug Administration's (FDA), MDA & CE Unique Device Identification (UDI) regulation to identify medical devices. The UDI label contains information in human- and machine-readable form, which includes the serial number, date of manufacture and Product name. The label is located on the stretcher frame as per the photo above

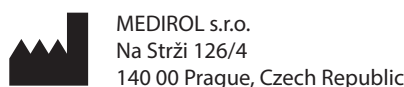

Ferno (UK) Ltd.
Ferno House, Stubbs Beck Lane
Cleckheaton, West Yorkshire, BD19 4TZ
+44 (0) 1274 851999



1 - SAFETY INFORMATION

1.1 Warning

Warning safety alerts indicate a potentially hazardous situation that, if not avoided, could result in injury or death.

WARNING

Untrained helpers can cause injury or be injured. Trained operators must operate the controls and direct helpers where to hold the VIPER stretcher to avoid pinch points.

Improper use of the stretcher can cause injury. Use the stretcher only for the purpose described in this manual.

Improper charging can cause injury and damage. Charge the battery only with an approved adapter and charger or integrated charging system (ICS).

Modifying the battery can cause injury and damage. Use the battery only as designed by Ferno.

Use only the original charging adapter. Using a non-original adapter may cause damage to the product.

Do not connect the external charging adapter when the stretcher is in use or with patient on it. There is a risk of injury to the operator and patient.

When connected to an external AC voltage network, the stretcher meets the requirements of protection class I. To avoid the risk of electric shock, the stretcher must be connected to a power network with protective earthing.

Improper maintenance can cause injury and damage. Maintain the stretcher and battery only as described in this manual.

Pushing the stretcher by the backrest may cause it to tip and injure the patient and/or operators. It is recommended to roll the stretcher only by holding the main frame or telescopic frame.

Loading the stretcher to ambulance with telescopic frame retracted can cause injury and damage. Make sure the telescopic frame is fully extended and locked before loading.

Do not connect the connectors to a voltage higher than 15 V. There is a risk of serious injury to the patient and damage to the product.

Improper operation can cause injury. Operate the stretcher only as described in this manual.

An unattended patient can be injured. Stay with the patient at all times.

An unrestrained patient can be injured. Use patient restraints to secure the patient on the stretcher.

Do not extend or retract the legs when tilted more than 30° relative to the horizontal plane. There is a risk of damage to the product.

Uncontrolled movement can cause injury or damage. Support and control the stretcher at all times.

Sheets or other objects can interfere with, or become entangled in, the actuator or legs, which can cause injury and/or malfunction, including unexpected retracting of the stretcher legs. Tuck sheets between the mattress and the patient surface. Keep other articles above the mattress.

WARNING

Rolling the stretcher sideways can cause it to tip and injure the patient and/or operators. Roll the stretcher only toward the control end or loading end.

Trained operators must consider the environment and terrain before rolling. Rolling the stretcher in a lowered position will minimise the potential of a stretcher tip.

Failure to load the stretcher within the loading height range can cause injury or serious damage to the product. Operators must ensure the stretcher is locked and captured by the VIPER Loading System before trying to retract the legs.

When unloading do not press the release button before the legs have touch the ground and has stopped automatically. Failure to do so can cause injury or serious damage to the product.

Never put your fingers in the sliding grooves, there is a risk of injury.

Improper maintenance can cause injury and damage. Maintain the stretcher and battery only as described in this manual.

The battery can be damaged if not charged for a long time. The battery must be fully charged at least once every two months.

Attaching improper items to the stretcher can cause injury. Use only Ferno-approved items on the stretcher.

Modifying the stretcher can cause injury and damage. Use the stretcher only as designed by Ferno.

Do not use the stretcher in areas with active high-frequency equipment (eg RF surgical instruments) and high EM interference (eg shielded MRI rooms where EM interference is high).

1.2 Notice

Notices emphasise important but not hazard-related information. Failure to follow Notices could result in product or property damage.















NOTICE

1.3 Blood borne Disease Notice

To reduce the risk of exposure to blood or other potentially infectious materials when using the stretcher, follow the disinfecting and cleaning instructions in this manual.

1.4 Symbol Glossary

The symbols defined here are used on the stretcher and/or in this manual. Ferno uses symbols recognized by the International Standards Organization (ISO), American National Standards Institute (ANSI) and the emergency medical services industry.

Symbol	Definition
	General warning of potential injury
	Pinch point. Keep hands clear
	No hands area. Do not remove finger guard
	Read the users' manual
	Two trained operators required
	Lubricate
	Do not lubricate
	Lock
	Unlock
	Load Capacity/Safe Working Load
	Type B applied part
	Temperature limit
IP 66	IP rating
	Duty cycle
	E8 homologation certificate

1.5 Safety and Instruction Labels

Safety and instruction labels place important information from the users' manual on the stretcher. Read and follow label instructions. Replace worn or damaged labels immediately.

Symbol	Definition
A	Ratings Label: Duty cycle, IP rating, General injury warning, Read the users' manual, Stretcher load capacity
B	Manual override release handle (Non-powered lower/raise legs)
C	Control buttons
D	Directional wheel locks
E	Minimum and maximum load height indicator
F	Backrest adjusting
G	Leg positioning platform adjusting
H	Knee gatch adjusting



1.6 Compliance

When properly installed and used with appropriate Ferno products, the stretcher meets or exceeds the following specifications and standards listed below. Standards and specifications are updated periodically. Current standards are available from these organizations.

STANDARDS MET

- **IP66:** Ingress Protection rating. Tested in compliance with dust and water infiltration standards
- **IEC 60601-1-2:** Temperature and vibration testing
- **EN 1789 and EN 1865:** Vehicle, fastening system, and crash-test standards

2 - OPERATOR FOCUS

2.1 Operator Training

Operator using the stretcher:

- Must read and understand this manual
- Must have training on proper use of the stretcher (and loading system)
- Must have a training on emergency-medical service and emergency patient-handling procedures
- Must have the physical ability to assist the patient
- Must practice with the stretcher before using it with a patient
- Must keep training records. For a sample training record sheet, see “Training Record” on page 38

2.2 Daily Operator Duties

It is good practice for operators to check equipment at the start of each work shift. To check the stretcher and loading system prior to use, follow the procedures described in this manual:

- Unload the stretcher from the ambulance. Visually inspect the stretcher for readiness
- Conduct the Daily Electrical Inspection and also check the function of the manual override release handle. See “Inspecting the Stretcher” on page 30.
- Rotate the stretcher in a circle to verify it rolls easily.
- Load the stretcher into ambulance and secure it in the VIPER Loading System.
- Verify the stretcher is being charged by the integrated charging system. Refer to the VIPER Loading System users’ manual.

2.3 Terms

The following terms are used in this manual.

- **CONTROL END (Foot End):** The end of the stretcher with the operator controls.
- **EXTEND (Legs):** Movement of the patient surface away from the transport wheels. Extend the legs to increase the overall height of the stretcher.
- **HELPER:** A trained helper works under the direction of the trained operators. Trained operators direct helpers where to stand and how to hold the stretcher.
- **INTEGRATED CHARGING SYSTEM (ICS):** The ICS charges the battery each time the stretcher is secured in the VIPER Loading System. (Power to the ICS from the ambulance must be ON).
- **LIFT-ASSIST:** Under extreme loads, the operators may need to provide lift-assistance. Use additional trained helpers if needed. See “Using Additional Help” on page 7.
- **LOAD:** The overall weight placed on, or attached to, the stretcher (patient plus equipment).
- **LOAD CAPACITY:** The amount of weight the stretcher is designed to hold, including patient and accessories such as IV poles, defibrillators, bags, etc.
- **LOADING END (Head End):** The end of the stretcher with the backrest and telescopic frame.
- **LOADING HEIGHT:** The level at which the stretcher will roll into and load onto the VIPER Loading System. Extend the stretcher to the loading height when loading it into an ambulance or unload it from an ambulance. Users can program a loading height for a designated ambulance. See “Set the Loading Height” on page 34.
- **RETRACT (Legs):** Movement of the patient surface closer to the transport wheels. Retract the legs to reduce the overall height of the stretcher.



WARNING

Untrained helpers can cause injury or be injured. Trained operators must operate the controls and direct helpers where to hold the VIPER to avoid pinch points.

2.4 Operator Height and Strength

The stretcher is designed to minimize the need for lifting. Whenever possible, use the powered hydraulic system.

A non-powered operation, may require the operators to lift a portion of the load. Use additional trained help as needed.

- **Ambulance:** When not using power, both operators must lift and hold the weight of the stretcher, patient, and equipment until the stretcher is held by loading system during the process to enter the ambulance with no power.
- **Rolling:** Operators/helpers must keep both hands on the main frame, support and balance the load, and maintain control of the stretcher at all times. Use caution on rough or uneven terrain.

2.5 Using additional help when available

Operating the stretcher requires a minimum of two trained operators. They may need additional trained helpers when working with heavy loads (patient plus equipment), or when operating the stretcher manually.

- Two trained operators stand at the loading end and control end of the stretcher, maintain control of the stretcher, operate the controls, and direct helpers on where to stand and how to hold the stretcher.
- Side helpers may need to walk sideways under some circumstances. Follow local protocols.
- Ferno recommends helpers work in pairs to help maintain stretcher balance from side to side

NOTICE

If the ambulance is parked on an uneven surface, the operators (and any helpers) may need to raise or lower the legs from the user-set loading height to allow the stretcher to be loaded into and out of the loading system.

Refer to the chart for suggested placement for operators and helpers.

- **Supporting Weight:** Supporting the weight of the stretcher, patient and equipment requires greater strength from short operators than from tall operators, because short operators must raise their arms higher relative to their shoulders.
- **Manual Override:** When using Manual Override to move the stretcher legs, an assistant operator must retract or extend the stretcher legs. See "Manual Override" on page 26.

WARNING

Untrained helpers can cause injury or be injured. Trained operators must operate the controls and direct helpers where to hold the stretcher to avoid pinch points.



Load Capacity

Inspect the VIPER if the load capacity has been exceeded. See "Inspecting the Stretcher" on page 30.

Using Additional Help when Available

Helpers	Changing Levels	Rolling	Loading/Unloading
2 Operators + 2 Helpers			
2 Operators + 4 Helpers			

Key: O = Operator H = Helper P = Patient

3 - ABOUT THE STRETCHER

3.1 Description

The Ferno® VIPER Stretcher is an emergency patient-handling device designed to transport a patient in a ground-based ambulance.

The stretcher is for professional use by a minimum of two trained operators and is designed for use with VIPER Loading System only.

The hydraulic power-lift system helps reduce the risk of back injury to medical service personnel by raising and lowering the stretcher, reducing the amount of lifting and bending for the operators. A manual override system is available for non-powered operation to allow the stretcher to be loaded and unloaded without power, by overriding the actuators and moving the legs manually.

3.2 Compatible Products

The stretcher is compatible only with manufacturer-approved restraint systems and VIPER Loading System. Contact your Ferno representative for the most recent cross-compatible stretcher, stretcher fastener and patient restraint system information.



WARNING

Improper use of the stretcher can cause injury. Use the stretcher only for the purpose described in this manual.

FEATURES

- Hydraulic actuator
- Integrated battery with battery management system
- Manual override for non-powered operation
- Height-control buttons
- Patient surface height range 380 mm-1330 mm (15"-52.3")
- Programmable loading height up to max 950 mm (37.4")
- Telescopic frame, shortening from 2000 mm to 1600 mm
- Lift bar and rubberized hold surfaces
- Battery status lights integrated into control panel
- Adjustable pneumatic backrest and leg positioning platform
- 150 mm swivel transport wheels
- Wheel locks (at foot-end)
- Directional wheel locks at head-end, operated at foot-end
- Patient harness and 2 leg straps
- Loading-end scuff guards
- Bolster mattress

CONFIGURATIONS

- **Accessories.** Your stretcher may be shipped with accessories per your order, such as 3-stage telescoping IV pole, PacRac equipment platform, and stretcher side Medical rail. These items are also available separately. Please refer to user manual supplied with these accessories for operating procedures.

3.3 General Specifications

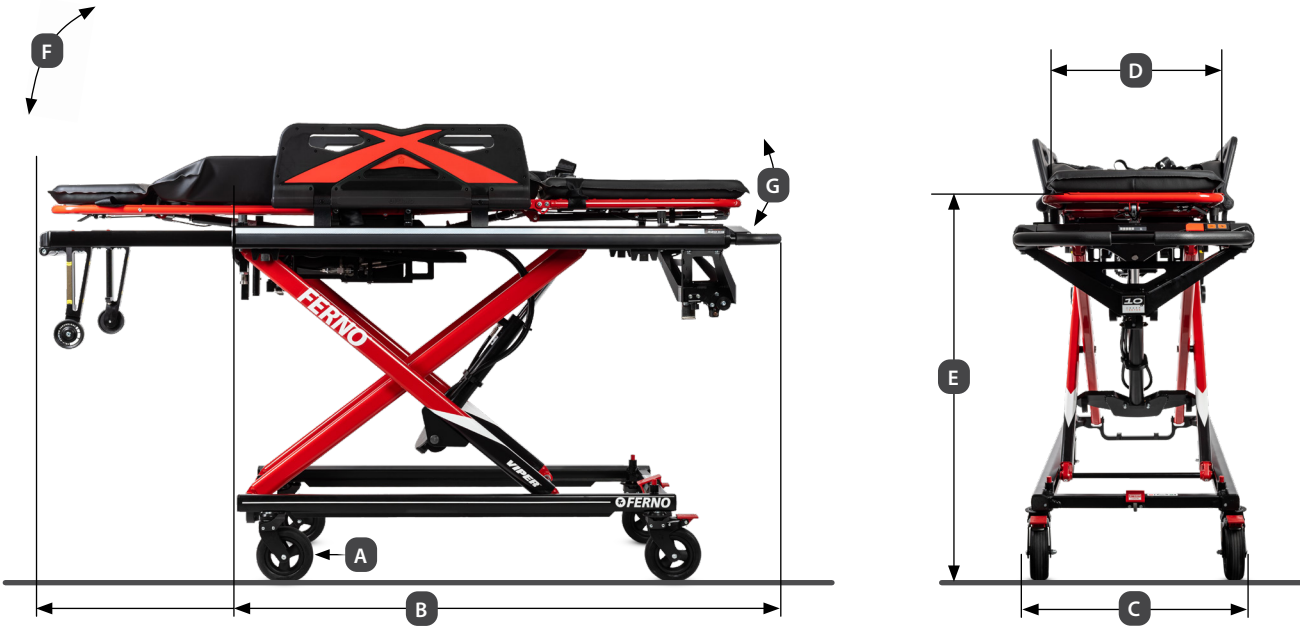

Dimensions	Metric	Imperial
A) Wheels	150 x 50 mm	6" x 2"
B) Length (Minimum-Maximum)	1600 mm - 2000 mm	63" - 79"
C) Width of stretcher / with SX cot sides extended horizontal	600 mm / 950 mm	24" / 37.4"
D) Width (Patient Surface)	460 mm	18"
E) Height ¹ (Minimum-Maximum)	380 mm - 1330 mm	15" - 52"
F) Backrest Adjustment		0° - 90°
G) Leg Positioning Platform Adjustment		0° - 30°
Loading Height (User-Programmable)	Max 950 mm	37.4"
Load Capacity (Unassisted)	320 kg / 50 stone	705 lbs
Stretcher Weight ²	74.88 kg	165 lbs
including SX cot sides, knee contour, mattress and harness	82 kg	181 kg
Max angle of incline (stretcher angle versus loading arm) when loading		-5° to + 7°
Max angle of lateral incline (side-angle) when loading		7°

Power System	
Charger Operating Range	-30°C to 70°C / -22°F to 158°F
Charger Output	48V, 3.34 A
Battery Operating Range	0°C to 65 °C / °32F to 149°F
Battery Output	37 VDC, 5Ah
Recommended Max Operating Duty Cycle	<24 sec ON; >120 sec OFF
Charging Time ⁴	Constant charging when in vehicle
Charging Time when fully depleted	Approx. 4.5 hrs
Input	100-240 VAC, 50/60 Hz, 2.0A

Soft Goods	
Mattress	1884 x 458 mm / 74.17" x 18.03"

Construction	
Frame, Legs, Bed Surface	Aluminum
Wheels	Stainless steel bearings

General specifications are rounded. Metric conversions are calculated before rounding. Ferno reserves the right to change specifications without notice.

¹ Stretcher height is distance from the ground to the patient surface at the seat panel.

² Weight includes battery but without SX cot sides, leg knee contour, mattress, patient restraints, or any optional features.

⁴ Integrated charging system maintains the battery charge when the stretcher is secured in the VIPER Loading System. Stretcher goes into sleep mode after 10 minutes to preserve battery charge when stretcher not being used and awoken by pressing the up or down button. Sleep time interval configurable in Service App.

4 - FEATURES AND OPTIONS



Control End



Loading End

4.1 Control End

The stretcher has height-control push buttons and a manual override handle for non-powered operation.

NOTE: The stretcher is ready for use whenever the battery is charged, and automatically goes into Sleep Mode when not in use to preserve the battery. Pressing either up and down button will bring the stretcher out of sleep mode.



STRETCHER HEIGHT-CONTROL / LEG-CONTROL BUTTONS

Stretcher height-control / leg-control buttons are located on the foot-end of the stretcher (Figure 1).

The arrow above the horizontal line on the button denotes the movement of the trolley (up or down) when out of the vehicle and the button is pressed.

The arrow below the horizontal line on the button denotes the movement of legs (raise or lower) when loaded onto into the loading arm, prior to loading/unloading in and out of the vehicle.

EXTEND: Extends the legs (raise the stretcher when on the ground / lower the legs when stretcher is on the loading arm)

RETRACT: Retracts the legs (lower the stretcher when on the ground / raise the legs when the stretcher is on the loading arm)

The buttons can also be used to set the load height of the stretcher. Hold both height-control buttons (A) together for 5 seconds to set the automatic loading height stop position for a designated ambulance. See "Set the Loading Height" on page 34.

RELEASE BUTTON (B)

This button unlocks the stretcher from VIPER Loading System. This function operates only when unloading the stretcher from ambulance.

MANUAL OVERRIDE RELEASE HANDLE (C)

This handle overrides the stretcher's powered actuator system allowing operators to be able to raise or lower the stretcher manually and load/unload the stretcher into/out of the vehicle if for whatever reason the stretcher battery is depleted and unable to recharge the battery. To use the manual override system, see "Manual Override" section on page 26. Use additional trained helpers as needed. See "Using Additional Help" on page 7.

NOTICE

Pressing extend or retract button while the stretcher is locked in a VIPER Loading System can damage the stretcher and fastening system. Do not press buttons while the stretcher is in ambulance.



VIPER STRETCHER BATTERY (E)

The integrated 37 V battery is a rechargeable battery with capacity of 5000 mAh and a battery management system (BMS) to extend its life.

When secured in the VIPER Loading System with a powered integrated charging system, the stretcher hydraulic system is disabled, ensuring it cannot be moved up or down when loaded.

Battery Features:

- Press any height control button to display the approximate battery charge (1 to 5 bars)
- **(D) Charging indicator lights (5):** When the control height button is pressed, the number of lights illuminated indicates approximate battery charge. Lights flash green when the battery is charging in the vehicle on the loading system or when charging with the supplied external mains battery charger when outside the vehicle.
- **(E) Temperature icon:** A blue flashing symbol indicates a low battery temperature. A red flashing symbol indicates a high temperature of one of the electronic components. If the problem persists, inspect the stretcher.
- **Sleep Mode:** After a period of inactivity, the stretcher will enter Sleep Mode to conserve battery power. Press any height-control button on the transporter to wake the transporter from Sleep Mode.
- **Charging:** The integrated charging system (ICS) uses power from the ambulance electrical system to automatically charge the battery while the stretcher is secured in a VIPER Loading System. Alternatively, it is possible to charge the stretcher outside of the vehicle using the supplied external mains charger which connects to the connector under the backrest (Figure 4). The recommended ambient temperature for charging the battery is 0°C - 25°C. Charge the battery in a stable temperature environment.
- **Balancing:** During balancing the voltages on the individual cells of the battery are equalized. This process starts when the battery has been fully charged and may take several tens of minutes. Battery Balancing is indicated by flashing all five indicator lights.

NOTICE

Fully charge the battery immediately upon receipt of the stretcher and before using the stretcher. Shipping regulations require the battery to be shipped with a maximum 30% charge. Failure to charge the battery in a timely manner can damage the battery.

To charge a battery inside an vehicle, use a VIPER Loading System with integrated charging system.

Charge Ferno batteries only with a compatible Ferno charger.

NOTICE

A fully charged new battery allows approximately 50 lifts cycles with a load of 100 kg. This value is indicative only.

As the battery ages and the number of charge cycles increases, the number of lifts per fully charged battery decreases. This is a natural process.

WARNING

Improper charging can cause injury and damage. Charge the battery only with an approved adapter and Ferno charger or integrated charging system (ICS).

Modifying the battery can cause injury and damage. Use the battery only as designed by Ferno.

Use only the original charging adapter. Using a non-original adapter may cause damage to the product.

Do not connect the charging adapter when the stretcher is in use or with patient on it. There is a risk of injury to the operator and patient.

When connected to an external AC voltage network, the stretcher meets the requirements of protection class I. To avoid the risk of electric shock, the stretcher must be connected to a power network with protective earthing.

When the battery capacity drops below 20%, start charging as soon as possible. There is a risk of the electronic system shutting down when battery charge drops below 20%

Fully charge and balance the battery at least once every 2-4 weeks, depending on how often you use the stretcher. There is a risk of battery failure if this is not followed.

Improper maintenance can cause injury and damage. Maintain the stretcher and battery only as described in this manual.

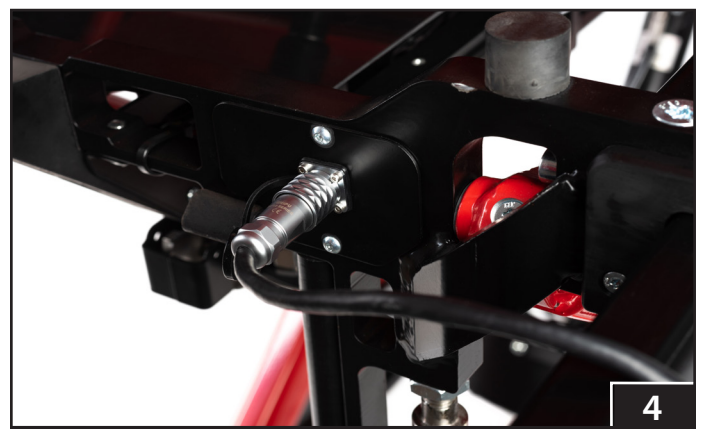
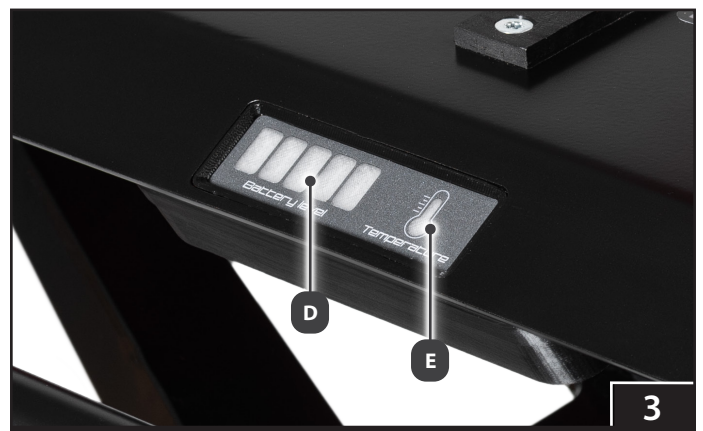

4.2 Patient Surface

The Viper bolster mattress is designed for maximum patient comfort and safety. It is designed to remain in place during patient transfer on or off of the stretcher and is easy to remove for cleaning.

The telescopic frame at head-end shortens the stretcher frame when space is limited.

Adjustable leg positioning platform and ratcheting SX surface extender sidearms are included as standard.

LEG POSITIONING PLATFORM

The leg positioning platform elevates the patient's feet or knees for patient comfort or for various medical requirements. Follow local protocols when deciding which position to use.

A pressurised gas spring aids raising and lowering of the leg platform. With a heavy patient, support the leg platform while making any adjustments. With a lighter patient, control the upward movement of the leg positioning platform so it does not move too quickly.

Leg positioning platform (F) with Knee-Gatch (Knee contour bend) (I):

1. Hold the frame with hand. Support the weight of the patient on the leg positioning platform.
2. Squeeze leg elevation or knee-bend control handle (G, H) toward the frame to unlock the gas spring, then raise or lower the leg platform (Figure 5) or knee-bend (Figure 6) accordingly to the desired position.
3. Release the control handle to lock the gas spring.

NOTICE

Leg positioning platform is designed to carry the weight of patient's legs. Patient must not sit on this part of the stretcher (especially when elevated) to avoid damage of gas spring and subsequent potential injury.

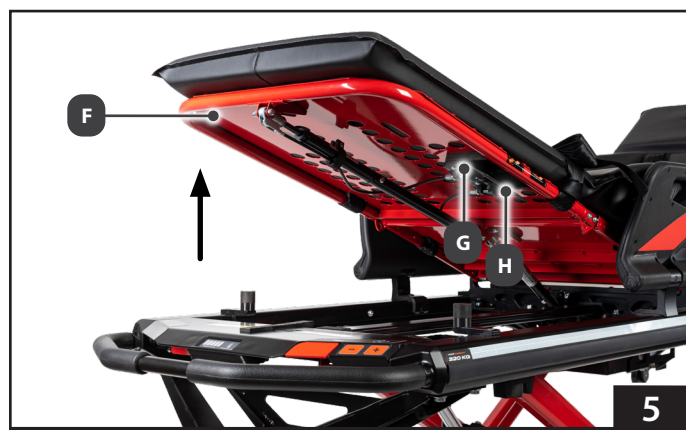

BACKREST (J)

The backrest (J) adjusts between 0°-90° to elevate the patient's torso for comfort or for medical requirements. Follow local protocols when deciding to change positions, and always operate the backrest from behind the backrest at the loading end of the stretcher, ensuring to hold the backrest at all times.

The backrest incorporates a gas spring to aid raising and lowering. With a heavy patient, always support the backrest whilst making any adjustments. With a lighter patient, ensure to control the upward movement of the backrest to avoid it moving too quickly.

1. Unfasten or loosen the restraints before changing positions.
2. Working from the loading end of the stretcher positioned behind the backrest, hold the backrest frame (J) with both hands. Support the weight of the patient and any equipment on the backrest.
3. Squeeze the control handle toward the backrest frame to unlock the backrest (Figure 7), then raise or lower the backrest to the desired position.
4. Release the control handle to lock the backrest.
5. Fasten and adjust the restraints after changing positions.

 **WARNING**

Pushing the stretcher by the backrest may cause it to tip and injure the patient and/or operators. Roll the stretcher only by holding the main frame or telescopic frame.

NOTICE

Backrest is designed to carry the weight of patient's torso. Patient must not sit on this part (especially when elevated) to avoid damage of gas spring.

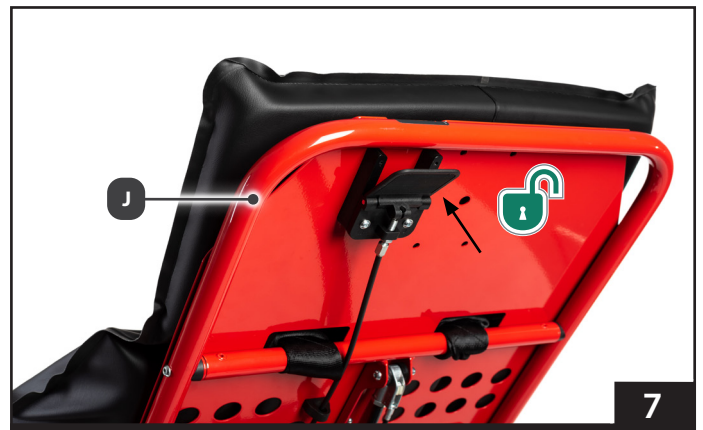

SX SURFACE XTENDER COTSIDES (K)

The SX surface extender cotsides provide added patient security and comfort, and increases the width of the patient surface allowing flexibility for large patients. SX cotsides also provides a location to place a patient's arm to start an IV etc. Each side locks individually. There are five locking positions and an unlocked, 'down' position. (Figure 8).

The SX cotsides has a safety feature which prevents the release mechanism from being overloaded. If the release handle is operated while there is weight on the cotside, the lock will not release. Lift up on the SX cotside to support the weight and release the lock before lowering.

To raise the SX cotside: Rotate the SX up to the desired position. There is no need to use the lock release.

To lower the SX cotside: Lift the SX slightly and move away from you to take the weight off the locking mechanism, then squeeze the red lock release (Figure 8) and lower the cotside to the desired position.



TELESCOPING FRAME

Use the telescoping frame (Figure 9) to shorten the stretcher and improve maneuverability in tight spaces (Figure 10). There are two locked positions: fully extended and retracted (retracts the frame to shorten the stretcher to its minimum length when used with a raised backrest).

- Use only a locked position when lifting the stretcher.
- The telescoping frame **must** be locked in the fully extended position before loading the stretcher into an ambulance or unloading the stretcher from an ambulance

Using the telescopic frame:

1. Loosen or unbuckle the waist strap if needed.
2. Raise the backrest.
3. Adjust and fasten the pelvis strap.
4. Hold and squeeze the telescoping frame release handle (Figure 9) towards the cross-bar and begin pushing or pulling the frame, then release the handle. Continue pushing or pulling the frame until it locks at the new position (fully in or out).



WARNING

Loading the stretcher to ambulance with telescoping frame retracted can cause injury and damage. Make sure the telescoping frame is always fully extended and locked before loading.

MATTRESS (L)

The mattress is designed to provide patient security and comfort. The VELCRO® pads on the mattress bottom (M) attach to the patient surface (Figure 11). The head section includes restraint slots to allow the restraints to be routed over the patient's shoulders.

- **To Attach:** Lower the backrest and/or leg positioning platform. Place the mattress on VELCRO® pads (Figure 12).
- **To Remove:** Disconnect the VELCRO® pads with both hands and remove the mattress.

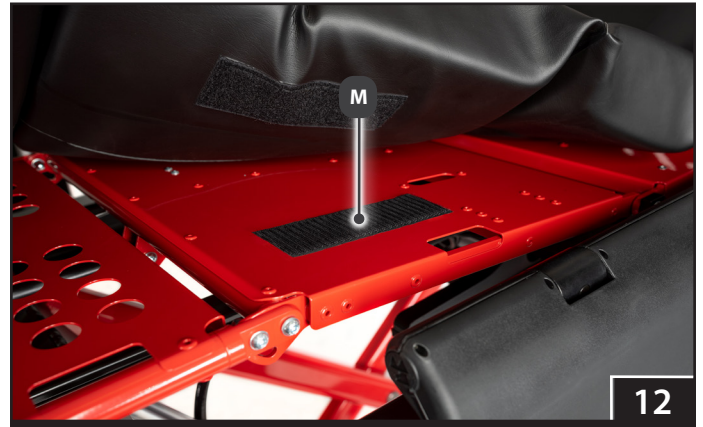

4.3 Stretcher Monobloc Frame

The Viper stretcher is raised and lowered using a hydraulic system, used also to extend and retract the legs when loading and unloading on the Viper Loading System (VLS). The stretcher has a 320 kg (705 lb) load capacity, the VLS rated at 400 kg. The rigid design of the stretcher frame provides advanced stability during rolling.

The fastening-system posts allow the stretcher to be secured safely in VIPER Loading System. The stretcher includes foot-end wheel brakes and head-end directional wheel locks that are actuated at the foot-end.



INTEGRATED CHARGING SYSTEM

The Integrated Charging System (ICS) uses power from the ambulance electrical system to automatically charge the battery while the stretcher is secured in a VIPER Loading System, using a 12v input.

BUTTON LOCKOUT



Button function is locked out to prevent accidental use when the stretcher is being charged.



WARNING

Do not connect the connectors to a voltage higher than 15 V. There is a risk of serious injury to the patient and damage to the product.

NOTICE

Pressing  or  while the stretcher is locked in a fastening system can damage the stretcher and fastening system. Do not press buttons while the stretcher is in the fastening system.

WHEEL BRAKES (N)

The foot-end wheel brakes help keep the stretcher from moving during patient transfer and certain medical procedures. Wheel brakes are on the foot-end (control-end) transport wheels (Figure 14). To engage the lock, press the lever down. To unlock, press the top of the lever (or lift the lever from below)

DIRECTIONAL WHEEL LOCKS (O)

- Directional wheel locks (Figure 15), (O) allow the operators to lock the direction of both head-end (loading-end) transport wheels in line with the length of the stretcher.
- To lock, press the top of lock lever located at the foot-end of the stretcher. The directional wheels will lock automatically when they align with the length of the stretcher when start to move the stretcher. To unlock, press the opposite end of the lever to disengage and allow 360° swivelling of the head-end wheels.

NOTICE

Wheel brakes are not a substitute for operator control. The operators must remain with the stretcher and keep control of it at all times. Never leave the patient unattended.

Verify that directional wheel lock lever is in locked position before you push the stretcher inside the ambulance to avoid the risk of the wheels colliding during unloading.

Wheel locks are not brakes. Do not use wheel locks to slow a moving stretcher.

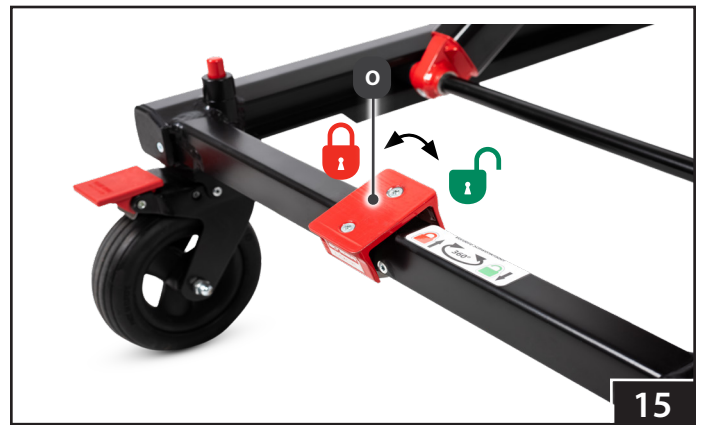
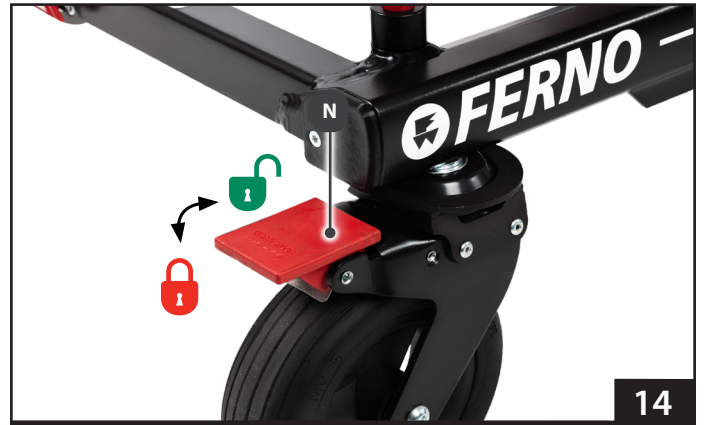

5 - USING THE STRETCHER

5.1 Before Placing the Stretcher in Service

- Before use, personnel who will work with the stretcher must read and understand this manual. Appropriate skills and training are required. See "Operator Skills and Training" on page 6.
- Prepare the stretcher for use, including setting the loading height for the designated ambulance. Refer to "Initial Setup" and "Set the Loading Height" on page 34.
- Confirm the stretcher operates properly. See "Inspecting the Stretcher" on page 30.
- The ambulance must have a VIPER Loading System installed.

5.2 General Guidelines for Use

- Medical advice is beyond the parameters of this manual.
- It is the operators' responsibility to ensure safe practices for the patient and themselves.
- Talk to the patient. Communicate before making changes to the stretcher height, and during the loading and unloading procedures.
- A minimum of two trained operators is required.
- Follow standard emergency patient-handling procedures when operating the stretcher.
- **Operators work together and maintain control of the stretcher at all times.**
- Operators **must** communicate with one another and use coordinated movements to operate the stretcher.
- Operators **must** stay with the patient at all times.
- **Always** use patient restraints to secure the patient on the stretcher.
- Use additional trained helpers when working with heavy loads (patient and equipment). See "Using Additional Help" on page 7.
- **Use only VIPER Loading System for loading/unloading and fastening the stretcher in the ambulance.** Read the VIPER Loading System users' manual for instructions on using the loading and fastening system.
- **Sleep Mode:** After a period of inactivity (default setting 10 minutes which can be changed using the Service App), the stretcher will enter Sleep Mode to conserve battery power. Press any button to wake the stretcher from Sleep Mode.
- The operating temperature range is 0 °C to +65 °C. The stretcher can be used for a short time (maximum 30 minutes) even in very low temperatures down to -30 °C. The system is equipped with a thermal fuse that protects important product components from damage due to low or high temperatures.
- The specified operating temperature range of the battery is between 0 °C to +65 °C.

- The system is equipped with a thermal fuse such that that if the battery core temperature drops below 0 °C degrees or above +65 °C, the stretcher will switch itself off, thereby protecting important product components from damage due to low or high temperatures.
- The stretcher can be used in lower ambient temperatures, down to as low as -30 °C, but is recommended to use for short periods of time only (maximum 30 minutes)

WARNING

Improper operation can cause injury. Operate the stretcher only as described in this manual.

An unattended patient can be injured. Stay with the patient at all times.

Avoid long-term exposure to low or high temperatures. There is a risk of damage to the product.

An unrestrained patient can be injured. Use patient restraints to secure the patient on the stretcher.





Load Capacity

Inspect the VIPER if the load capacity has been exceeded. See "Inspecting the Stretcher" on page 30.

5.3 Powered Extending/Retracting

Extending or retracting the legs with a patient on the stretcher requires a minimum of two trained operators who are communicating, working together, and maintaining control of the stretcher at all times.

Be aware that the stretcher automatically stops at the minimum height, user-set loading height, and at the maximum height.

- Both Operators/Trained Helpers:** Keep both hands on the stretcher main frame. Maintain control of the stretcher so it does not shift when extending or retracting the legs. During the position change, move with the stretcher and maintain your hold on the main frame.
- Control-end (Foot-end) Operator:** Press any height-control button to wake the stretcher from Sleep Mode, then press  or  to extend or retract the legs until the stretcher reaches the desired height (Figure 16).

PROVIDING LIFT ASSISTANCE

The stretcher load capacity is 320 kg / 705 lb. Loads exceeding this limit may require lift-assistance from operators/trained helpers. If the stretcher will not extend the legs, follow the procedure below. Always maintain control of the stretcher with both hands on the main frame.

Use additional trained helpers as needed to safely control the weight of the patient and stretcher. See “Using Additional Help” on page 7.

- Both Operators/Trained Helpers:** Operators stand at opposite ends of the stretcher and use an underhand grip (palms up) to hold the stretcher frame at foot-end and head-end. Direct trained helpers where to stand and how to hold the stretcher.
- Control-end Operator:** Communicate with the Loading-end Operator and trained helpers, then press .
- Both Operators/Trained Helpers:** Allow the stretcher to lift the load. Provide only as much lift assistance as is needed to adjust the stretcher height. Together, extend the stretcher to the desired height and hold the stretcher at that position.
- Both Operators/Trained Helpers:** Slowly lower your hands to verify the stretcher has stabilized at the new position.

WARNING

Do not extend or retract the legs when tilted more than 30° relative to the horizontal plane. There is a risk of damage to the product.

Do not exceed the maximum prescribed operating duty cycle (See Technical Specification on page 9). There is a risk of system shutdown due to overheating.

Uncontrolled movement can cause injury or damage. Support and control the stretcher at all times.

NOTICE

A slight lift may occur shortly after pressing  button. In this way, the system optimizes the legs retracting according to the load. This is not a malfunction.







16



5.4 Transferring the Patient

Note that if the load (patient plus equipment) exceeds the load capacity, the stretcher legs may not extend when a button is pressed, and/or the stretcher may move downwards several centimeters after stopping. See “Providing Lift Assistance” on page 21.

To transfer a patient onto the stretcher:

1. Place the stretcher beside the patient. Press  or  to adjust the stretcher to the patient's level (Figure 17).
2. Lock the wheel locks. If needed, lower the SX Surface Xtenders.
3. Unfasten the patient restraints on the stretcher. Arrange the straps so they will not interfere with transferring the patient onto the stretcher.
4. Transfer the patient onto the stretcher using approved emergency- medical procedures and following local protocols.
5. Adjust the backrest, leg positioning platform or SX cotsides as needed for patient comfort or medical care.
6. Fasten and adjust the patient restraints.
7. Before moving the stretcher or changing its position, confirm that sheets, blankets and other articles will not interfere with stretcher operation.
8. Unlock the wheel locks.
9. Press  or  until the stretcher reaches the desired height (Figure 17).

To transfer a patient off of the stretcher:

1. Roll the stretcher near to the destination surface. Press  or  to adjust the patient surface to, or slightly above, the destination surface.
2. Lock the wheel locks. If needed, lower the SX.
3. Unfasten the patient restraints. Arrange the straps so they will not interfere with transferring the patient off the stretcher.
4. Transfer the patient onto the destination surface using approved emergency-medical procedures and following local protocols.
5. Fasten and arrange the patient restraints so they will not interfere with using the stretcher.
6. Before rolling the stretcher or changing its position, confirm sheets and other articles will not interfere with stretcher operation, unlock the wheel locks, and adjust the stretcher height as needed.

WARNING

Sheets or other objects can interfere with or become entangled in the actuator or legs, which can cause injury and/or malfunction, including unexpected retracting of the stretcher legs. Ensure to tuck sheets between the mattress and the patient surface. Keep other articles above the mattress.

NOTICE

Sheets or other articles can become caught in the locking mechanism. Tuck sheets between the mattress and the patient surface. Keep other articles above the mattress.





5.5 Rolling the Stretcher

Rolling the stretcher with a patient on it requires a minimum of two trained operators who are communicating, working together, and maintaining control of the stretcher at all times.

Use additional trained helpers as needed to safely control the weight of the patient and stretcher. See "Using Additional Help" on page 7.

Roll the stretcher on smooth, unobstructed surfaces whenever possible. Do not roll the stretcher sideways or push the stretcher using the backrest. Roll the stretcher only with both hands holding the stretcher main frame.

Full 360° Movement: The stretcher allows full maneuverability at any height, even when fully retracted.

1. Before rolling, fasten and adjust the patient restraints.
2. **Control-end Operator:** Press  or  to adjust the stretcher height (Figure 18).
3. **Both Operators/Trained Helpers:** Operators position themselves at the ends of the stretcher, hold the main frame with both hands and maintain control of the stretcher. Direct trained helpers where to stand and how to hold the stretcher.

WARNING

Rolling the stretcher sideways can cause it to tip and injure the patient and/or operators. Roll the stretcher only toward the control end or loading end.

Pushing the stretcher by the backrest can cause it to tip and injure the patient and/or operators. Roll the stretcher only by holding the main frame.

Trained operators must consider the environment and terrain before rolling. Rolling the stretcher in a lowered position will minimize the potential of a stretcher tip.





5.6 Loading the Stretcher

Loading the stretcher into an ambulance with a patient on it requires a minimum of two trained operators who are communicating, working together, and maintaining control of the stretcher at all times. Use additional trained helpers as needed. See "Using Additional Help" on page 7.

To set the loading height, see "Set the Loading Height" on page 34.

1. Trained Operators:

- Raise the ambulance folding bumper, if one is present.
- Fully extend the loading arm of VIPER Loading System and verify that it is locked in position.
- **Ensure that the telescoping frame at head-end of the stretcher is fully extended**
- Align the stretcher with, and keep it parallel to, the arms of VIPER Loading System during loading.

2. Control-End Operator: Press and hold  button to raise the stretcher to the pre-set loading height. **The stretcher height must be in range of yellow indicator markers at the head-end of the stretcher** (Figure 19). If not, press  or  to adjust accordingly.



3. Operators/Trained Helpers: Roll the stretcher towards the ambulance and the extended loading arm, aligning the stretcher approximately in line with the loading arm head. Keep pushing the stretcher over the loading arm until the loading arm starts moving into the vehicle and continue until it will move no more and the stretcher has locked into the VIPER Loading System (Figure 20). Confirm the stretcher is secure by pulling it slightly outwards from the ambulance.

4. Loading-End Operator: Confirm the stretcher has been locked and captured by the VIPER Loading System.

5. Control-End Operator: Press  and keep held to completely retract/raise the stretcher legs (Figure 21)

6. Both Operators/Trained Helpers: When stretcher legs have fully retracted/raised, the loading arm of VIPER Loading System is automatically unlocked such that it can then be moved fully into the vehicle. Push the stretcher into the ambulance until stretcher locks in fastening system.

7. Either Operator: Confirm the stretcher is secure in the fastening system. The loading arm red release handle must be in horizontal position (Figure 22). If the VIPER Loading System is equipped with connected ICS, confirm the ICS is charging the battery by checking the indicator lights on the control panel.

Button Lockout: Do not try to press  or  button while the stretcher is inside the ambulance. Also refer to "Lockout" on page 18.



19

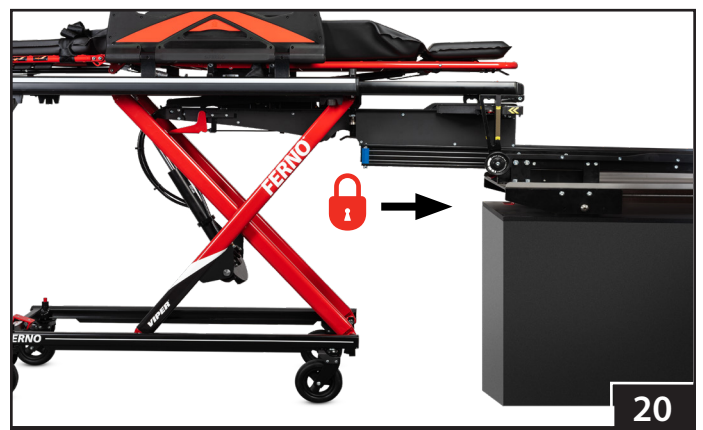

20

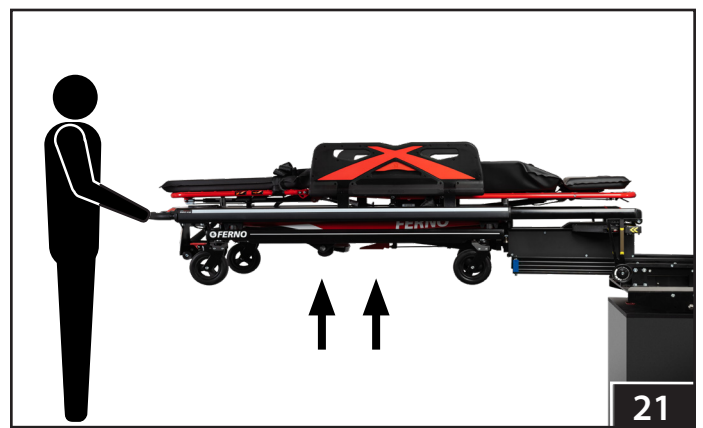

21

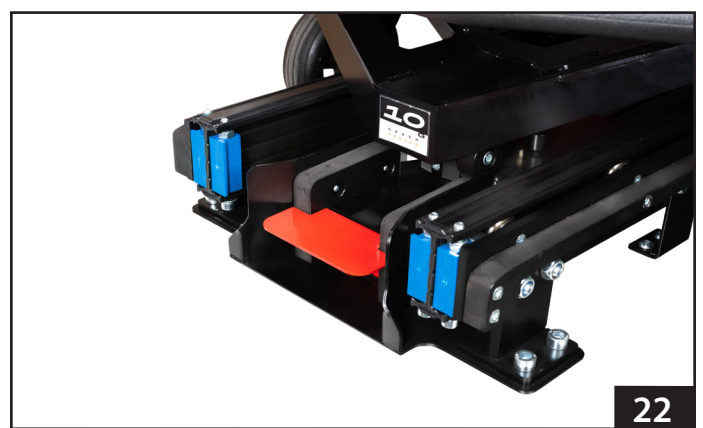

22

WARNING

Failure to load the stretcher within fit the loading height range during loading can cause injury or serious damage to the product. Operators must ensure the stretcher is locked and captured by the VIPER Loading System before retracting the legs.

NOTICE

If the ambulance is parked on an uneven surface, the operators may need to extend the legs higher than normal loading height to allow the stretcher to lock into the VIPER Loading System.

5.7 Unloading the Stretcher

Unloading the stretcher from an ambulance with a patient on it requires a minimum of two trained operators who are communicating, working together, and maintaining control of the stretcher at all times. Use additional trained helpers as needed. See "Using Additional Help" on page 7.

- 1. Loading-end Operator:** Raise the ambulance folding bumper, if present.
- 2. Control-end Operator:** Push the red release handle (P) on the VIPER Loading System.
- 3. Both Operators/Trained Helpers:** Hold the stretcher with both hands. Roll the stretcher out of the ambulance until it stops and will move no more and the mechanical spring slightly holds the stretcher in the unloading position (Figure 24). The spring does not provide sufficient protection against reverse movement. Always hold the stretcher firmly in the unloading position.
- 4. Control-end Operator:** Press and hold  button. The legs will extend and automatically stop once they have touched the ground and lifted the stretcher slightly.
- 5. Control-end Operator:** Press the release button on the stretcher to disengage it from the VIPER Loading System (Figure 25).
- 6. Both Operators/Trained Helpers:** Roll the stretcher completely out of the VIPER Loading System. Keep the stretcher parallel with the extended arm of VIPER Loading System during rolling.
- 7. Control-End Operator:** Adjust the stretcher height before rolling. See "Rolling the Stretcher" on page 23.

5.8 One Operator, Empty Stretcher

If local protocols permit, an empty stretcher (no patient) may be operated by one trained operator. Always use two operators whenever a patient is on the stretcher.

Raising/Lowering: Press  or  to adjust the stretcher height.

Loading and Unloading: Follow the procedures as for two operators. See "Loading the Stretcher" on page 24 or "Unloading the Stretcher" on page 25.



WARNING

Do not press the release button before the legs touch the ground and stop automatically. Failure to do so can cause injury or serious damage to the product.

NOTICE

If the ambulance is parked on an uneven surface, the operators (and any helpers) may need to extend or retract the legs to move the stretcher from the normal loading height to allow the stretcher to roll into the ambulance.

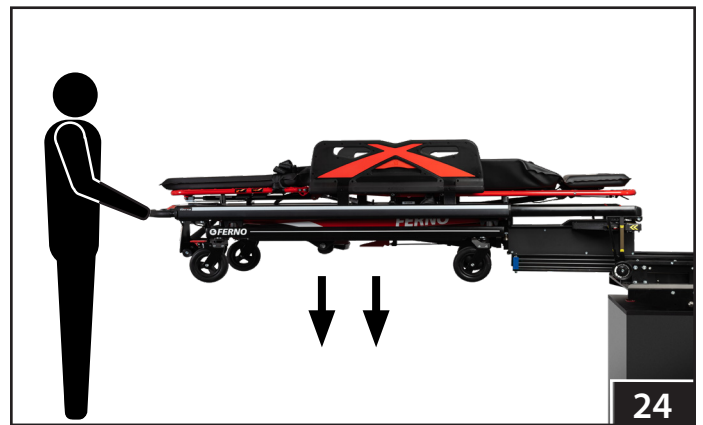
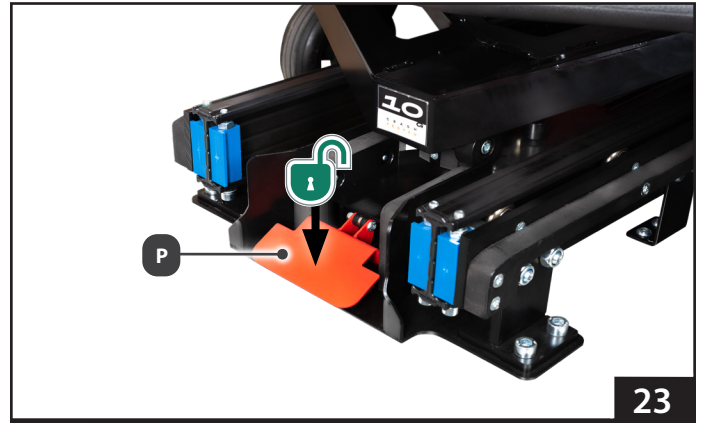

5.9 Manual Override

If for whatever reason the stretcher battery charge has been fully depleted and unable to recharge, the actuator manual override system can be used to operate the stretcher and allow the stretcher still to be lowered/raised and loaded/unloaded without power. This does require some additional manual handling, especially when raising the stretcher or loading the stretcher so use additional trained helpers as needed. See "Using Additional Help" on page 7.

Note: The manual override handle (Q) will not function unless the weight has been lifted off the leg locking mechanism. This is a safety feature to help prevent accidental retracting of the legs.

EXTENDING OR RETRACTING USING MANUAL OVERRIDE

- Both Operators/Trained Helpers:** Stand at opposite ends of the stretcher and hold the main frame with an underhand grip (palms up).
- Both Operators/Trained Helpers:** Lift the stretcher slightly to lift the weight off the leg locking mechanism.
- Control-End Operator:** Pull the manual override handle only long enough to make the position change.
- Both Operators/Trained Helpers:** Together, raise or lower the stretcher to the desired height, then hold the stretcher at that position (Figure (26)).
- Control-End Operator:** Release the manual override handle to lock the stretcher at the desired height.
- Both Operators/Trained Helpers:** Slowly lower your hands to confirm the stretcher has stabilized at the new position.

WARNING

The manual backup mode is not intended for routine handling. Use it only in case of electronic failure and only for necessary actions.

NOTICE

If the ambulance is parked on an uneven surface, the operators (and any helpers) may need to extend or retract the legs from the user-set loading height to allow the stretcher to roll into the ambulance.



LOADING USING MANUAL OVERRIDE

To load the stretcher into an ambulance without stretcher power, follow the loading instructions in this manual, with the following differences:

- Both Operators/Trained Helpers:** Adjust the stretcher to loading height position using. See "Extending or retracting" in manual override mode on page 26.
- Both Operators/Trained Helpers:** Roll the stretcher towards the ambulance until the stretcher locks into the VIPER Loading System (Figure 27). Confirm the stretcher is secure by pulling it slightly outwards from the ambulance.
- Both Operators/Trained Helpers:** Lift the stretcher slightly to lift the weight off the leg locking mechanism.
- Control-End Operator:** Pull and hold the manual override handle.
- Loading-End Operator:** Hold the undercarriage lower frame by the longitudinal beams so that the fingers rest on the outer surfaces (Figure 28).
- Loading-End Operator:** Raise the undercarriage as far as it will go to ensure to unlock the arm of VIPER Loading System to allow the stretcher to be loaded in.
- Complete the loading procedure as described in this manual for loading.
- Control-End Operator:** Release the manual override handle.

UNLOADING USING MANUAL OVERRIDE

To unload it from an ambulance, follow the unloading instructions in this manual, with the following differences:

- Control-end Operator:** Push the red release handle (P) on the VIPER Loading System.
- Both Operators/Trained Helpers:** As per normal procedure, holding the stretcher frame with both hands, roll the stretcher out of the ambulance until it stops and the mechanical spring slightly holds the stretcher in the unloading position (Figure 24). The spring does not provide sufficient protection against reverse movement. Always hold the stretcher firmly in the unloading position.
- Control-End Operator:** Pull and hold the manual back-up handle. The legs will extend and stop once they touch the ground. Keep holding the manual back-up handle for 3 seconds.
- Control-end Operator:** Press the release button to disengage the stretcher from the VIPER Loading System.
- Complete the unloading procedure as described in this manual.
- Note that since the stretcher will not be at the normal height as when unloading under power, make sure to support the stretcher at head-end at both sides when taking off the loading arm as there will be a slight drop when removing off.

WARNING

Never put your fingers in the sliding grooves, there is a risk of injury.

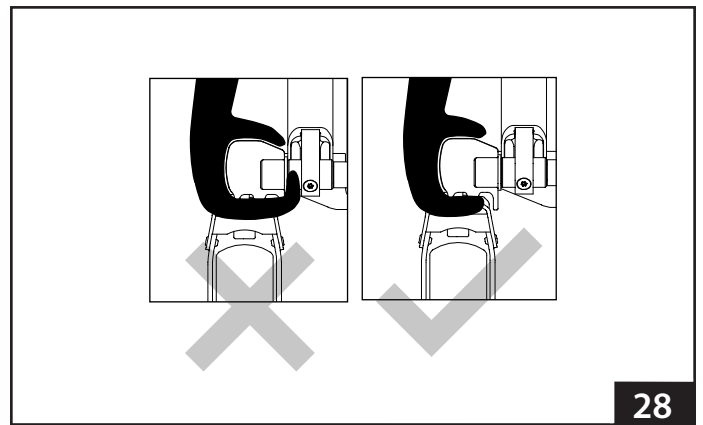

6 - MAINTENANCE

6.1 Maintenance Schedule

The stretcher requires regular maintenance. Set up and follow a maintenance schedule. The table at right represents minimum intervals for maintenance. Keep maintenance records. For a sample record sheet, see "Maintenance Record" on page 39.

When using maintenance products, follow the manufacturers' directions and read the manufacturers' material safety data sheets.

6.2 Service Life

Many factors affect a product's service life, including frequency of use (high-volume versus low-volume ambulance service); local environment (extreme temperature, high humidity, etc.); maintenance (adherence to the inspection and maintenance schedule); and other factors.

Follow the disinfecting, cleaning, and inspection procedures in this manual to ensure long life for the stretcher.

6.3 Lubrication-Free Stretcher

The stretcher is constructed with lubrication-free materials. Do not lubricate the stretcher. Applying lubricant can cause damage to the stretcher.

Do not lubricate the upper or lower sliding actuator bearings. As needed, clean only with soap and water. Rinse well to remove any soap residue.



WARNING

Improper maintenance can cause injury and damage. Maintain the stretcher and battery only as described in this manual.

Minimum Maintenance	Each Use or Daily	As Needed	Monthly
Daily Operator Duties (page 6)	•		
Disinfecting (page 29)	•		
Cleaning (page 29)	•		
Inspecting (page 30)		•	•

NOTICE

LUBRICATION-FREE Stretcher

Lubricating parts that should not be lubricated allows dirt and foreign particles to collect on those parts, resulting in damage.



6.5 Disinfecting and Cleaning the Patient Restraints

Remove the restraints from the stretcher before cleaning/disinfecting them.

To disinfect: Apply disinfectant to all restraint surfaces, following the disinfectant manufacturer's instructions for application method and contact time. Wipe with a clean cloth. Do not immerse the metal buckles in liquid.

To clean metal buckles: Apply a disinfectant cleaner to the metal buckle, following the disinfectant manufacturer's instructions for application method and contact time. Wipe with a clean cloth. Do not immerse the metal buckles in liquid.

To clean the webbing:

1. Add a disinfectant cleaner to warm water, following the disinfectant manufacturer's instructions.
2. Immerse webbing in the solution for the time directed by the disinfectant manufacturer. Do **not** immerse the metal buckle.
3. Repeatedly dip the webbing in clear water to rinse. Do not immerse the metal buckles in liquid.
4. Hang the restraint to air-dry.
5. Attach only dry restraints to the equipment.

6.6 Disinfecting and Cleaning the Mattress

Remove the mattress from the stretcher and inspect it. Replace the mattress if it is ripped, punctured or damaged.

To disinfect: Apply disinfectant to the mattress, following the disinfectant manufacturer's instructions for application method and contact time.

To clean: Wash the mattress with warm, soapy water and a soft cloth. Rinse the mattress with clear water. Hang the mattress to dry, or dry it with a towel.

6.7 Disinfecting the Stretcher

Wipe all surfaces with disinfectant. Follow the disinfectant manufacturer's instructions for application method and contact time. Ferno recommends you inspect the stretcher for damage as you disinfect it.

6.8 Cleaning the Stretcher

1. Remove the patient restraints, mattress and any accessories. Verify that all cords, cables, connectors, etc. are connected.
2. Hand clean all surfaces of the stretcher with warm water and a mild detergent. Do not spray water directly into ports, wire harnesses, cable connections, etc.
3. Rinse with warm, clear water. Dry the stretcher with a towel or allow it to air dry.

NOTICE

Disinfectants and cleaners containing phenolics or iodines can cause damage. Do not use products containing these chemicals. If bleach is used, rinse with plenty of clear water to remove bleach residue.

Using abrasive cleaning compounds or applicators on the stretcher can cause damage. Do not use abrasive materials to clean the stretcher.

Metal buckles and slide bars can be damaged by immersion in liquids or by washing-machine action. Disinfect and clean only as described in the restraint users' manual packaged with the restraints.

Water under high pressure or steam can penetrate joints, hinges and sealed bearings. Use caution when cleaning moving parts such as joints and hinges.

6.9 Inspecting the Stretcher

Inspect the stretcher regularly and keep maintenance records. See "Maintenance Record" on page 39. Have your service's equipment maintenance personnel follow the checklists on this page and operate the stretcher through all its functions as described in this manual.

A daily inspection is recommended at the start of each operator shift, including the manual override release handle and the electrical inspection on this page. See "Daily Operator Duties" on page 6.

If inspection shows damage or excessive wear, remove the stretcher from service until repair is made. See "Parts and Service" on page 36.

DAILY ELECTRICAL INSPECTION

- Do both sets of height-adjustment buttons function properly?
- Does the powered system operate properly through the full range of motion?
- Does the powered system operate smoothly, without binding or excessive noise?
- Does the actuator stop running at the user-set loading height, fully-extended and fully-retracted positions?
- Do all indicator lights on the control panel function?
- Is there visible sign of damage to the electrical box?
- Are all cords/cables free of excessive wear, cuts, and fraying?
- Does the integrated charging system charge the stretcher battery and prevent stretcher operation when the stretcher is secured in the VIPER Loading System?

MECHANICAL INSPECTION

- Are all components present?
- Is the stretcher free of excessive wear?
- Does the hydraulic power system operate smoothly, without excessive noise?
- Is all hardware securely in place?
- Do all moving parts operate smoothly and properly?
- Does the stretcher load and unload properly?
- Do the legs show signs of wear or damage?
- Does the manual override release handle function properly and is the cable free of excessive play?
- Does the stretcher roll smoothly?
- Do the wheels show excessive wear or damage?
- Do the wheel locks and directional wheel locks engage properly and function properly?
- Are the patient restraints properly installed?
- Is restraint webbing in good condition with no cuts or frayed edges?
- Are restraint buckles free of visible damage and do they operate properly?
- Can restraint strap length be adjusted properly?
- Is the ambulance properly prepared for the stretcher with a VIPER Loading System installed?
- Do installed accessories operate properly without interfering with stretcher operation?
- Are contacts of integrated charging system clean and make a good connection?

6.10 Storing the Stretcher

If the stretcher will not be in service for an extended period of time, prepare it for storage as follows:

1. Lower the stretcher to the fully-retracted position.
2. Charge the battery.
3. Switch off the stretcher by pressing the main switch button.

Before returning the stretcher to service:

1. Turn on the stretcher by pressing the main switch button.
2. Fully charge battery.
3. Have your service's equipment maintenance personnel inspect the stretcher. See "Inspecting the Stretcher" on page 30.

 **WARNING**

The battery can be damaged if not charged for a long time. The battery must be fully charged at least once every two months.

6.11 Patient Restraints

Always attach all patient restraints with the buckles at the same side for operator convenience and efficiency. To attach:

1. Unbuckle the restraint and separate the straps.
2. Wrap the loop end of a strap around the designated attachment point on the stretcher backrest (Figure 29), leg positioning platform (Figure 30 and 31) or seat panel (Figure 32).
3. Thread the male buckle/tang or female buckle/receiver through the loop and pull the webbing through the loop until the loop is snug around the attachment point (Figure 33).
4. Repeat Steps 2 and 3 to attach the other part of the strap to the selected attachment point on the opposite side of the stretcher.
5. Keep restraints buckled when not in use.
6. Ensure that all straps are correct and present on the stretcher as per figure 34 on page 33, including upper body 4-point harness consisting of 4 straps and 2 legs straps.

6.12 Removing the Restraints

1. Unbuckle the buckles.
2. To remove the restraint, unbuckle the restraint. Feed the buckle (or tang) through the loop, and remove the loop from the stretcher.

WARNING

An unrestrained patient can be injured. Use properly-installed patient restraints to secure the patient on the stretcher.

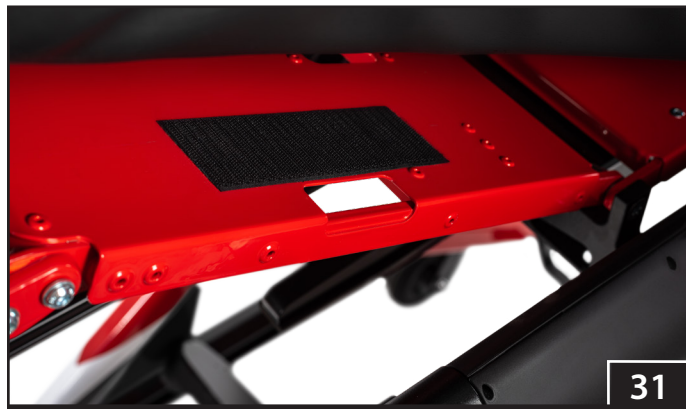

SECURING A PATIENT

When transporting or moving a patient on the stretcher, always ensure to use and deploy all parts of the patient restraint system, including the upper body harness and 2 leg straps.

To secure a patient on the stretcher (Figure 34):

1. Unbuckle the restraints and position the straps out of the way.
2. Transfer the patient onto the stretcher following local protocols. Adjust the backrest, leg positioning platform, and restraint length as needed.
3. Lay the shoulder straps (R) over the patient's shoulders and attach them across the patient's chest in an H-formation.
4. Fasten the pelvic restraint across the patient's pelvis (S).
5. Fasten the leg restraint over the patient's legs (T).
6. Adjust the restraints so they are snug on the patient.

SECURING A PATIENT

To lengthen a strap: Unbuckle the restraint. Hold the male buckle/tang and turn it perpendicular to the webbing and pull outward, away from the strap attachment point until the strap is the desired length.

To shorten a strap: Hold the hemmed tab and pull the webbing through the male buckle/tang until the strap is the desired length.



7 - INITIAL SETUP

7.1 Ambulance Information

The patient compartment should have a level floor large enough for the fully-lowered stretcher and the VIPER Loading System to be installed.

7.2 Restraints, Mattress, Accessories

Before placing the stretcher in service, assign appropriate personnel to install the mattress, patient restraints, and any accessories shipped with the stretcher, if not already fitted. Keep restraint and accessory users' manuals with this manual for future reference. For additional, free manuals, contact Ferno. See "Ferno Customer Relations" on page 2.

A set of patient restraints is provided. Attach patient restraints only as instructed in this manual. See "Patient Restraints" on page 32.

7.3 Turn on the stretcher

Turn on the stretcher by pressing the main switch button that is located at the bottom of electrical box in the middle of the stretcher (Figure 33). The main switch switches on the electronic circuits, and should be left permanently switched on.

Never switch off the stretcher while it is in use. There is a risk of serious damage to the product.

Switch off the stretcher only in case of long-term storage. See "Storing the Stretcher" on page 31.

7.4 Charge the Battery

Charge the battery immediately upon receipt until it has a full charge. To comply with shipping regulations, the stretcher is shipped with less than a 30% charge in the battery.

Charge the battery using **only** a Ferno battery charger or by securing the stretcher in a properly-connected and powered VIPER Loading System with a Integrated Charging System.

7.5 Set the Loading Height

The user can set the stretcher so it stops automatically at the proper loading height for the assigned ambulance. To set or change the loading height:

1. On a level surface, raise or lower the stretcher until the roller on the telescopic frame (U) is slightly above the VIPER Loading System head platform. Verify that the yellow arrows on the side of the VIPER Loading System are within the range of the yellow MIN-MAX indicator labels on the stretcher (Figure 35).
2. Press and hold **both** height control buttons for 5 seconds. Release the buttons only after the blue light has counted up to 5 bars and the indicator lights has then flashed quickly.
3. Retract and extend the legs to verify the stretcher stops at the new loading height. Test loading and unloading the stretcher with the ambulance.

WARNING

Never switch off the stretcher while it is in use. There is a risk of serious damage to the product.

Charge battery immediately upon receipt until it has a full charge.

Attaching improper items to the stretcher can cause injury. Use only Ferno-approved items on the stretcher.

NOTICE

Loose items and debris on the patient compartment floor can interfere with the operation of the stretcher with the VIPER loading system. Keep the patient compartment floor clear.



36

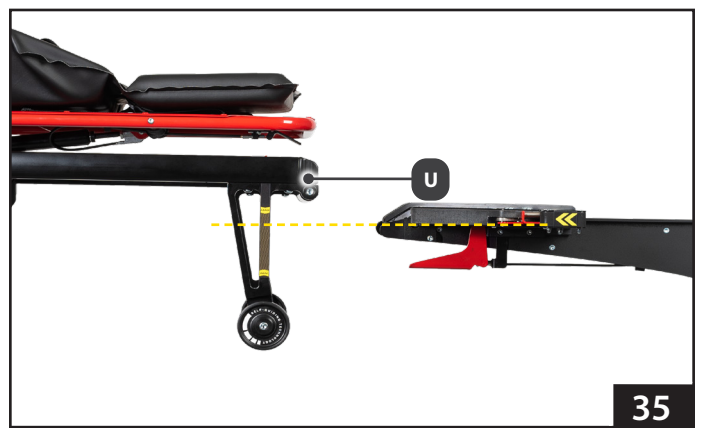

35

8 - ACCESSORIES

Ferno offers a full line of accessories approved for use with the stretcher. Follow all instructions in accessory users' manuals. Keep the instructions with this manual.

When using accessories, be aware of any special considerations such as doorway heights and widths, or other factors which may be affected by the addition of the accessory/accessories to the stretcher.

Contact Ferno Customer Relations (page 2) or your Ferno distributor for product information.



WARNING

Attaching improper items to the stretcher can cause injury. Use only Ferno-approved items on the stretcher.

9 - PARTS AND SERVICE

9.1 U.S.A. and Canada

In the United States and Canada, to order parts or for professional repair, contact EMSAR® – the only agent authorized by Ferno to manage, service, and repair Ferno products.

Telephone (Toll-Free)	1.800.73.EMSAR
Telephone	1.937.383.1052
Fax	+1.937.383.1051
Internet	www.EMSAR.com

9.2 Worldwide

To order Ferno parts, and for professional repair, contact your Ferno distributor. Your distributor is the only agent authorized by Ferno to manage, service, and repair Ferno stretchers.

9.3 Troubleshooting

The indicator lights help the user to identify an approaching problem in time and react appropriately to it. The following table contains a description and instructions for individual warning states. If the solutions do not resolve the situation, **contact your service partner immediately.**

Situation	Description	Cause	Solution
Temperature symbol flashes red	Electronics are in the high temperature zone. The system works without restrictions.	The stretcher is exposed to high temperatures for a long time.	Place the stretcher in an environment with a temperature below 30 °C.
		Overheating due to failure to observe the maximum duty cycle.	Reduce the height positioning frequency.
Temperature symbol flashes blue	Electronics are in the low temperature zone. The system works without restrictions.	The stretcher is exposed to low temperatures for a long time.	Place the stretcher in an environment with a temperature higher than 5 °C.
Five indicator lights flash orange	The motor current is in the high range. The system stops the engine when the condition is reached. It can then be reactivated immediately.	Exceeding the load limit of patient surface.	Lighten the patient area.
	The maximum allowed engine running time has been reached. The system stops the engine when the condition is reached. It can then be reactivated immediately.	High control button pressed for more than 15 seconds.	A long engine running time may be the result of a system malfunction. Contact an authorized service center immediately.
Five indicator lights illuminate red	Exceeding the range of high or low values of the parameters described in three previous situations.		Follow the instructions for the solution in previous situations.
	Low battery voltage.	Discharged battery.	Connect the charging adapter.
	Interrupted CANBUS communication.	Damage to the wiring or other part of the electronic system.	Contact an authorized service center immediately.
Five indicator lights illuminate yellow	System is connected to mobile service app. This is not a warning signal.		
Five indicator lights illuminate blue	Indicates change of the loading height. This is not a warning signal.		
No lights out	The system is shut down due to a fault or serious operating condition.	Battery fully discharged.	Connect the power adapter.
		System failure.	Contact an authorized service center immediately.

WARNING

Improper parts and service can cause injury. Use only Ferno parts and Ferno-approved service on the stretcher.

Modifying the stretcher can cause injury and damage. Use the stretcher only as designed by Ferno.

10 - ELECTRONIC COMPATIBILITY OF THE ELECTRONIC SYSTEM

The stretcher with electronic control unit is intended for use inside and outside the ambulance.

No required functionality is defined.

TABLE 1 - IMMUNITY TO RF WIRELESS COMMUNICATION EQUIPMENT

Test frequency (MHz)	Bandwidth (MHz)	Service	Modulation	Immunity test level V/m
385	380 - 390	TETRA 400	Pulse modulation 18 Hz	27
450	430 - 470	GMRS 460, FRS 460	FM \pm 5 kHz deviation 1 kHz sine	28
710 745 780	704 - 787	LTE band 13, 17	Pulse modulation 217 Hz	9
810 870 930	800 - 960	GSM 800/900, TETRA 800, iDEN 820, CDMA 850, LTE Band 5	Pulse modulation 18 Hz	28
1720 1845 1970	1700 - 1990	GSM 1800; CDMA 1900; GSM 1900; DECT; LTE band 1,3, 4, 25; UMTS	Pulse modulation 217 Hz	28
2450	2400 - 2570	Bluetooth, WLAN, 802.11 b/g/n, RFID 2450, LTE Band 7	Pulse modulation 217 Hz	28
5240 5500 5785	5100 - 5800	WLAN 802.11 a/n	Pulse modulation 217 Hz	9

INSTRUCTIONS AND MANUFACTURER'S STATEMENT - ELECTROMAGNETIC RESISTANCE

Radiation test	Conformity
Electrostatic Discharge (ESD) IEC 61000-4-2	\pm 8 kV for contact discharge \pm 15 kV for air discharge
Radiated high-frequency electromagnetic field IEC 61000-4-3	3 V/m 80 MHz - 2,7 GHz 80 % AM at 1 kHz
Near field from IEC high frequency wireless communication equipment 61000-4-3	See Table 1
A fast electrical transient/ group of impulses IEC 61000-4-4	\pm 2 kV for mains supply line repetition rate 100 kHz
A sudden impulse IEC 61000-4-5	\pm 1 kV conductor - conductor \pm 2 kV conductor - grounding
Immunity to line-borne and RF-induced interference IEC 61000-4-6	3 V (0.15 MHz - 80 MHz) 6 V in the ISM bands between 0.15 MHz and 80 MHz 80 % AM at 1 kHz
Mains frequency magnetic field (50/60 Hz) IEC 61000-4-8	30 A/m
Short-term voltage dips, short interruptions and slow voltage changes on the mains supply line IEC 61000-4-11	0 % UT; 0.5 cycle At 0°, 45°, 90°, 135°, 180°, 225°, 270° and 315° 0 % UT; 1 cycle and 70 % UT; 25/30 cycles Single phase: at 0° 0 % UT; 250/300 cycles

INSTRUCTIONS AND MANUFACTURER'S STATEMENT - ELECTROMAGNETIC EMISSIONS

Radiation test	Conformity
High frequency radiation / CISPR 11	Group 1 / Class B
Harmonic emissions / IEC 61000-3-2	class A
Voltage fluctuations / Flicker emissions / IEC 61000-3-3	suits

WARNING

Do not use the stretcher in areas with active high-frequency equipment (e.g. RF surgical instruments) and high EM interference (e.g. shielded MRI rooms where EM interference is high).

Avoid using the stretcher next to or in a block with other devices, as incorrect operation may be induced. If such use is necessary, observe both the stretcher and the devices for normal operation.

Modifying the stretcher can cause injury and damage. Use the stretcher only as designed by manufacturer.

NOTICE

No deviations from the requirements of IEC 60601-1-2 ed. 4
No other measures are known to maintain basic safety based on EMC phenomena.

TRAINING RECORD

Date	Printed Name	Signature	Training Method			Trainer Initials
			Read Manual	Video/ Online	Hands-On	

MAINTENANCE RECORD

Date	Maintenance Performed	By



70 Weil Way
Wilmington, OH 45177

Aviation

Military

Mortuary

EMS

Rescue
